

'03- GM ESCALADE/DENALI XL 6.0L V8

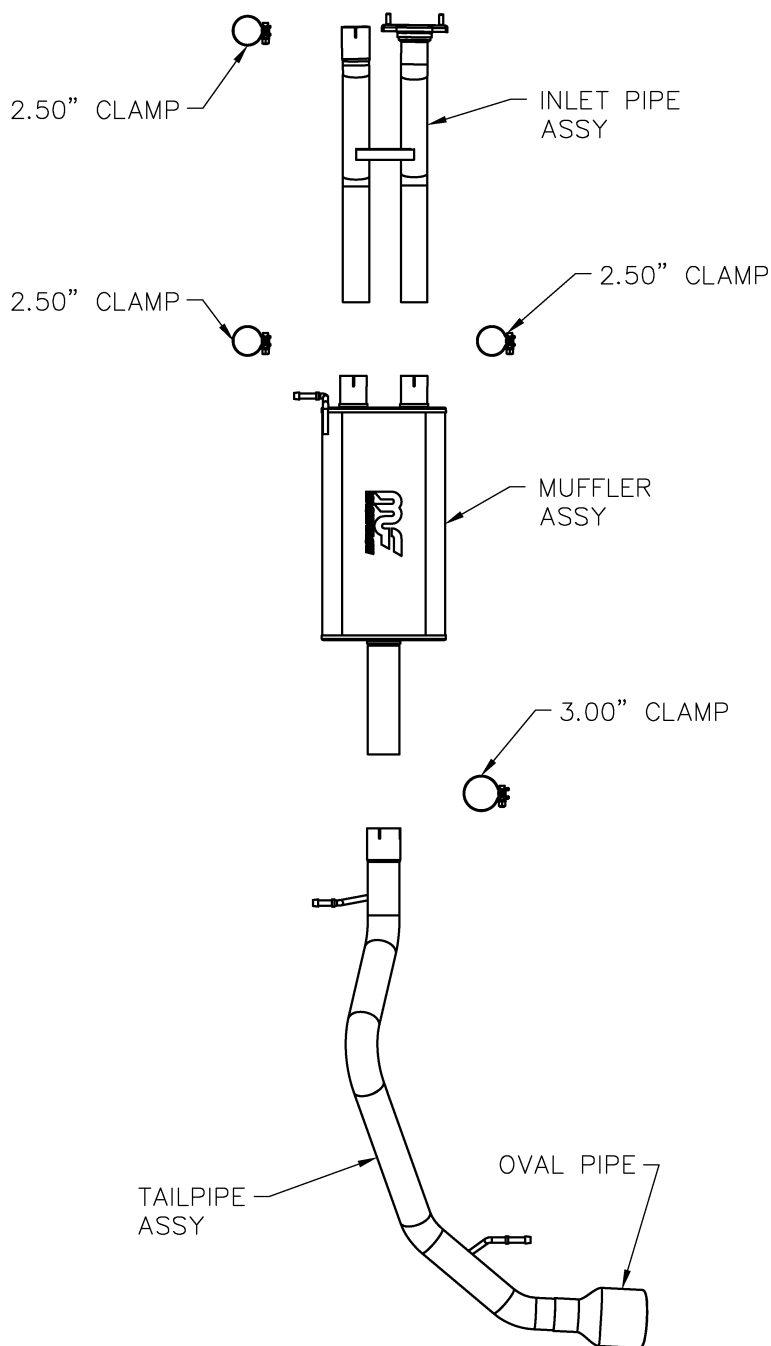

Warning: When working on, under, or around any vehicle exercise caution. Please allow the vehicle's exhaust system to cool before removal, as exhaust system temperatures may cause severe burns. If working without a lift, always consult vehicle manual for correct lifting specifications. Always wear safety glasses and ensure a safe work area. Serious injury or death could occur if safety measures are not followed.

Step 1: (Carefully read all instructions before installation) Disconnect the vehicle's battery before removal of the OEM exhaust. This will allow the computer to reset itself with the new system, and prevent electrical accidents. Remove the OEM exhaust system by cutting the tailpipe where the pipe meets with the Y pipe on the outlet side of the muffler. Once the tailpipe is cut, disengage the welded hangers on the tailpipe from the OEM rubber insulators. Do not damage the OEM rubber insulators, as they will be re-used to mount the new system. Continue to remove the system by un-bolting the system at the 2-bolt flange and clamp. Remove the rest of the system by disengaging the welded hangers.

Step 2: Mount the new system using a front to rear pattern. Using the OEM fasteners and a supplied 2.50" clamp, install the Inlet pipe assy. Leave all clamps and fasteners loose for final adjustment of the new system. Using two 2.50" clamps, install the muffler assy and insert the welded hanger to the OEM rubber insulator. Using the supplied 3.00" clamp, install the tail pipe assy and insert the welded hangers to the OEM rubber insulators.

Step 3: With all components mounted loosely, adjust the system for overall aesthetics and clearance of frame & bodywork. (MAGNAFLOW recommends at least 1/2" of clearance between the exhaust system and any body panels to prevent heat-related body damage or fire.)

Step 4: Once a final position has been chosen for the new system, evenly tighten all fasteners from front to rear. The supplied band clamps must be VERY tight to properly align the pipes and prevent leaks (Approximately 40ft-lbs). Inspect all fasteners after 25-50 miles of operation and retighten if necessary.

*MAGNAFLOW Performance Exhaust recommends professional installation on all their products

Technical support: 1-800-959-9226 ext. 4500