



PROFILE

PERFORMANCE

INSTALL GUIDE

VEHICLE-SPECIFIC PRISM HALOS

WARNING: By reading this document, I agree it is only to be used as an educational guide. Profile Performance nor its distributors make guarantees on any finished results, nor are they to be held responsible for any damage, misuse, or personal injuries. Use at your own risk. If you are unable to clearly understand and adapt the information below, professional installation is recommended.

WHAT'S INCLUDED



2-6x PRISM HALO



2-6x PRISM DRIVER

OPTIONAL COMPONENTS:



INSTALLATION WIRE



MORIMOTO XBT CONTROLLER



MORIMOTO RETRORUBBER

TOOLS REQUIRED



FLAT HEAD SCREWDRIVER



1MM DRILL BIT / DRILL



NEEDLENOSE PLIERS



SCISSORS



BROAD-NOSE PLIERS



HEAT-RESISTANT GLOVES



CONVENTIONAL OVEN

RECOMMENDED PROTECTION:



PROTECTIVE EYEWEAR

INSTALLATION

NOTE: For opening and resealing headlight housings, there can be many variables that can increase the level of installation difficulty. For most (not all) housings, the following steps outline both opening and resealing housings properly. Additional installation documentation is available via YouTube videos made by our dealers and distributors.

If at any point you are unable to or uncomfortable with the installation, stop your work and contact an authorized Profile dealer prior to proceeding further.



After removing any screws or clips along the perimeter of the light, place headlight in oven for seven (7) minutes at 270 F / 130 C to soften the existing sealant.

NOTE: Some housings have different sealant types that require other procedures to open and remove.

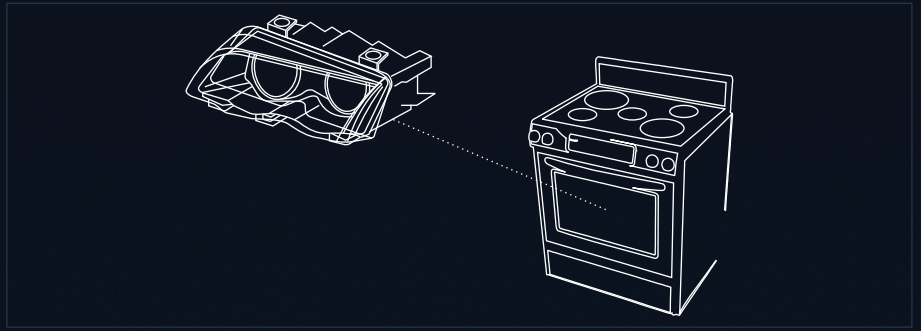

Using a flathead screwdriver, pry gently on the seam holding the two housing halves together to separate them.

NOTE: Gloves are recommended!

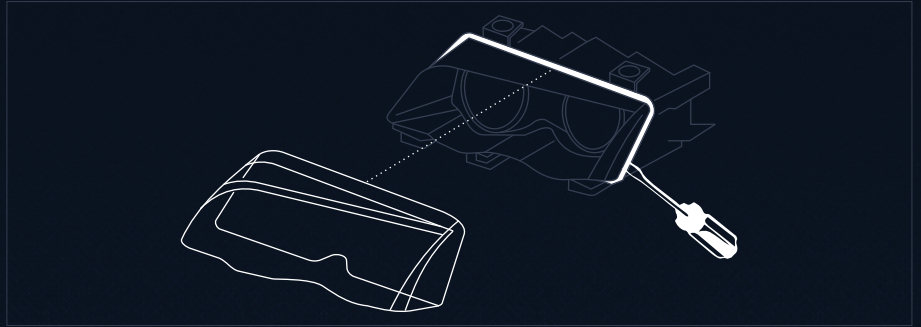

Allow thirty (30) minutes for headlight to sufficiently cool down prior to continuing.



Using the integrated MicroMounts, mark the housing or bezel both with the hole of the MicroMount and a second hole just outside of each MicroMount. This is where you will drill the housing/bezel to mount the halo.



You will need to access the back of the bezel or housing piece that you are mounting the halo to. The process of disassembly varies widely, but is as easy as inspecting the lamp to determine the process. Installation once completed will be the reverse of removal.

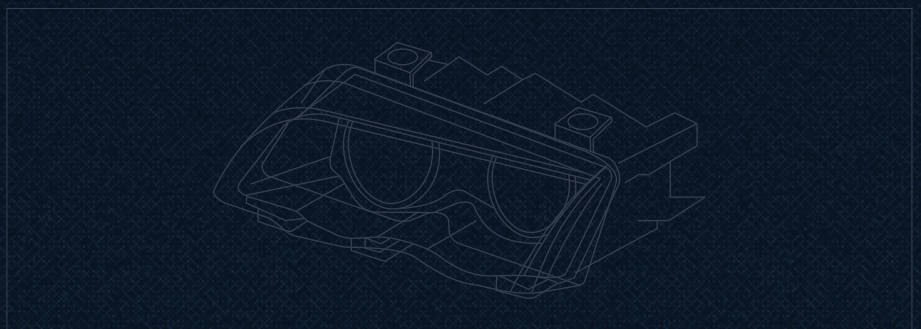

Drill a 1mm hole at each marked location from the previous step.

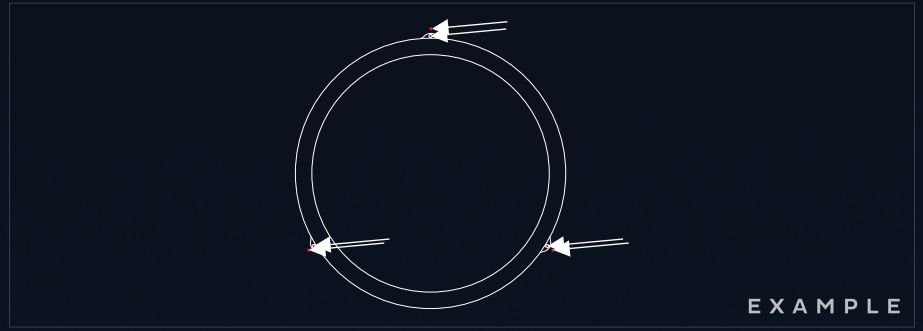

Using installation wire, beading wire, or fishing line, feed the wire from behind the housing/bezel, up and through the MicroMount, then back down through the housing/bezel. Then secure the halo by twisting the wire behind the housing or bezel.

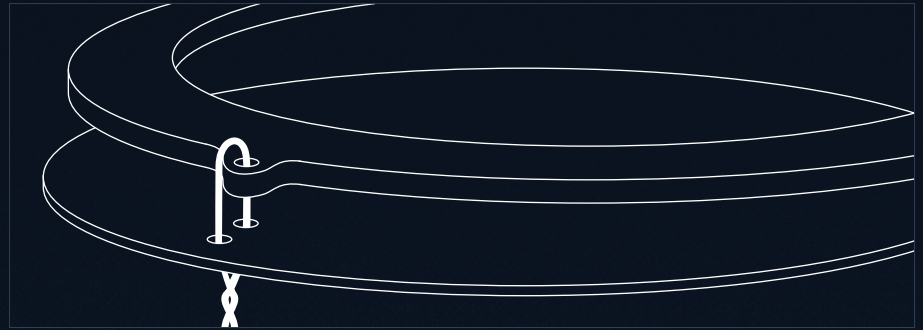

Place a bead of RetroRubber sealant in channel of headlight housing as shown. Fill the majority of the channel to ensure it sufficiently holds the front lens once re-installed.

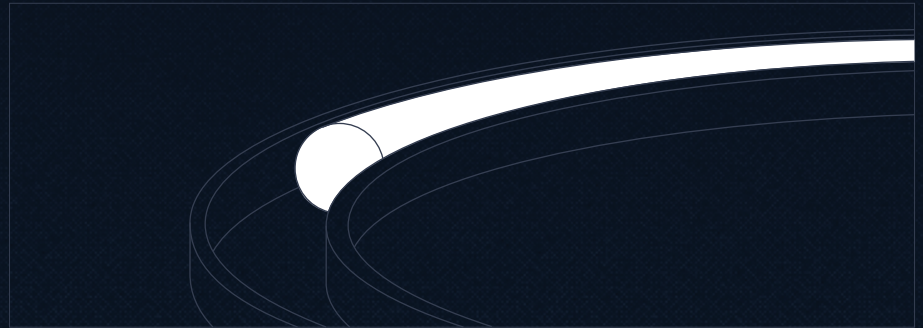

Use scissors to cut the RetroRubber once the entire circumference of the housing has been filled.



Re-fit the headlight lens back over channel in headlight housing and press gently.

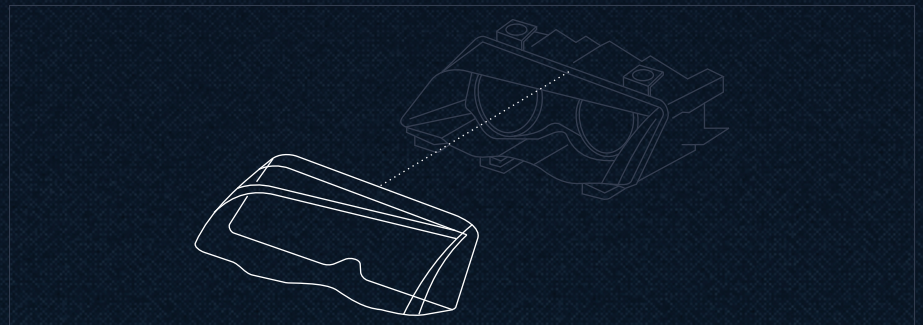

Place entire headlight in oven for seven (7) minutes at 270 Fahrenheit / 130 Celsius to soften the new sealant.

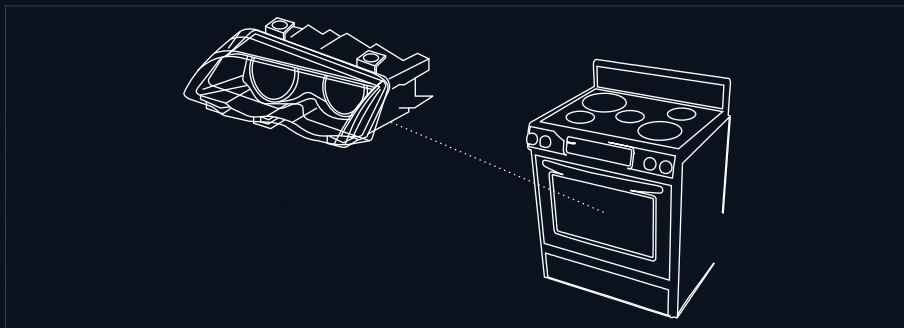

Using broad-nose pliers, squeeze the headlight channel back together snugly to ensure the RetroRubber creates a proper seal. Re-install any OEM clips or screws with the sealant still hot.



Allow thirty (30) minutes for headlight to sufficiently cool down prior to re-installation on car.



WIRING PROCESS

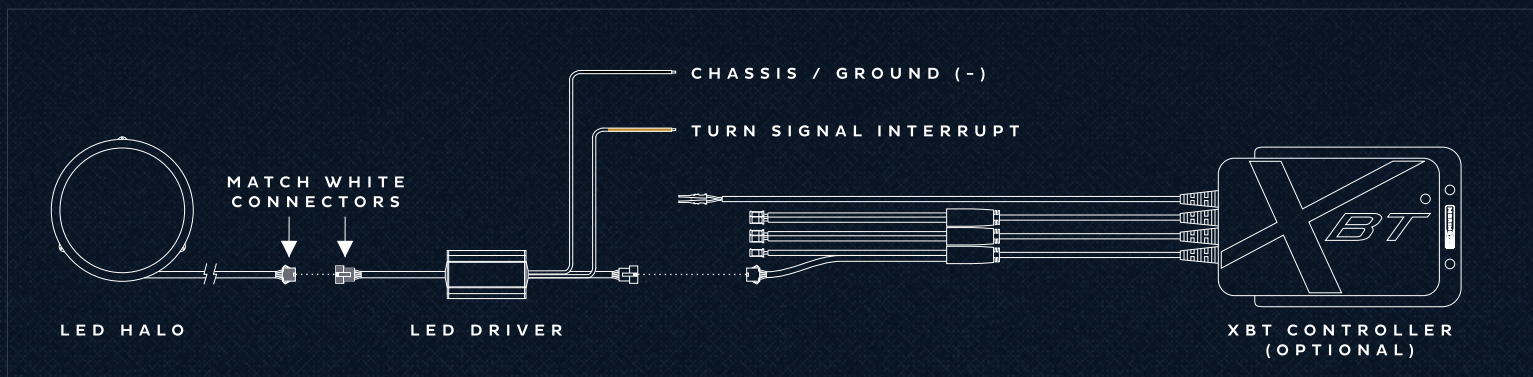

NOTE: The chassis / ground wire must be grounded to bare metal for the LED halo to function properly.

NOTE: The turn signal interrupt wire needs to be tapped or spliced into the 12V+ lead that has power when the turn signal is illuminated. This makes the RGB halo flash a common amber color as the turn signal.

